

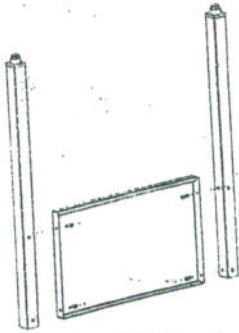

LAVATOI SU GAMBE
--
SINK UNITS ON LEGS

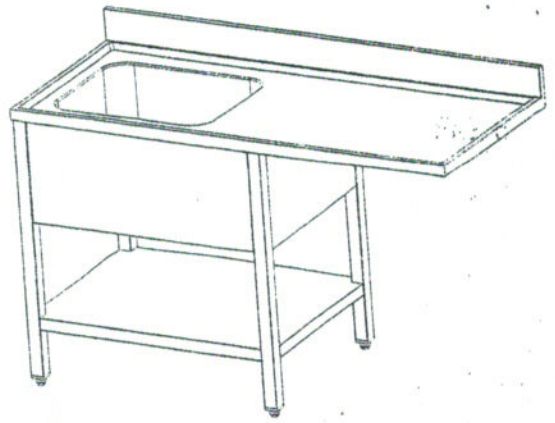

4 x L=20

FIG. 1

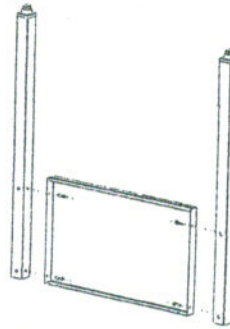

4 x L=20

FIG. 2

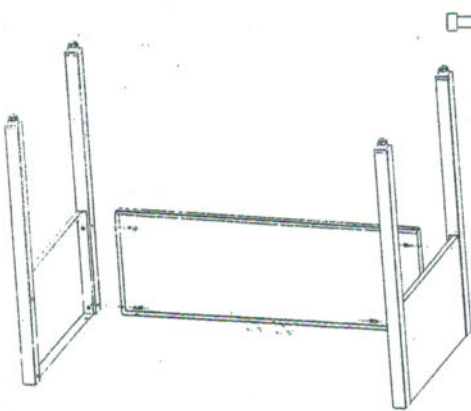

4 x L=20

FIG. 3

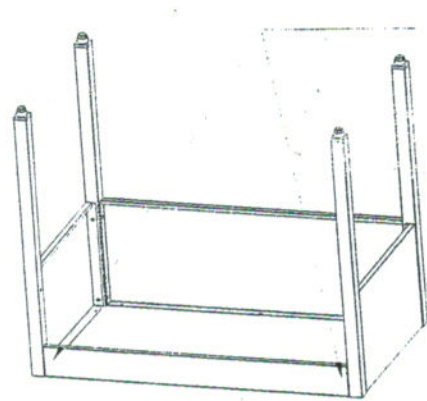

2 x L=20

FIG. 4

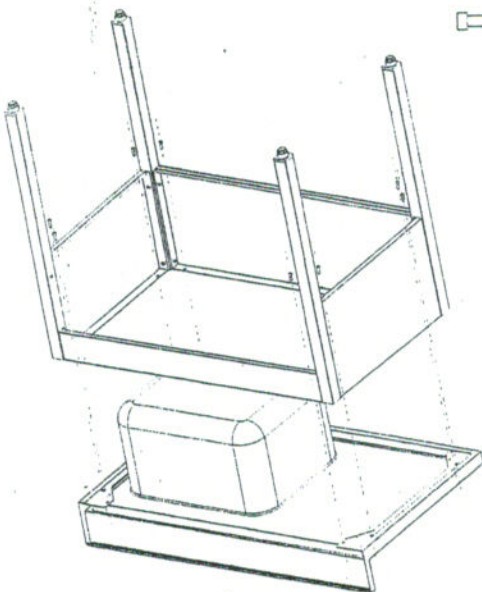

8 x L=20

FIG. 5

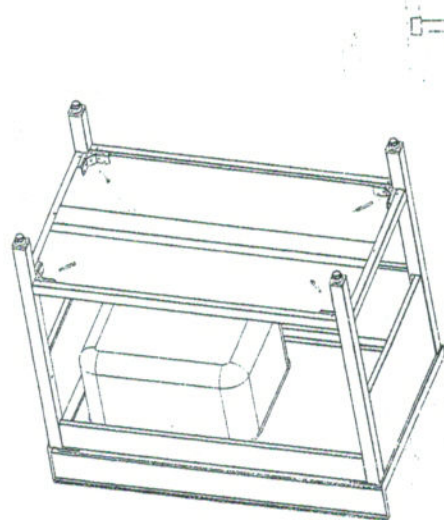

4 x L=45

FIG. 6